

# MP SERIES SEAL-LESS ROTARY VANE PUMPS

## INSTALLATION, OPERATION, AND MAINTENANCE INSTRUCTIONS

TO OBTAIN THE BEST PERFORMANCE FROM YOUR WARRENDER MP PUMP,  
PLEASE READ THIS MANUAL CAREFULLY.

**Failure to follow the recommended procedures may result in early and severe damage to your WARRENDER pump, and may also invalidate the guarantee.**

Thank you for your purchase of a WARRENDER MP Series rotary vane pump.  
Proper installation and maintenance will provide many years of trouble free operation.

### **INSTALLATION:**

**1) LOCATION:** Locate the pump close to the liquid source.

**2) PRIMING:** The MP pump will self-prime. The pump will prime without liquid in the unit.  
( *Please Consult the Factory if the pump is expected to lift prime* )

### **3) SYSTEM PIPING:**

**a)** The nominal diameters of the pump ports shall not be taken as reference for piping size selection. The pipe diameter shall be selected according to the involved capacity and associated frictional losses. The inlet pipe should be no smaller in diameter than the nominal bore of the pump inlet port. As a general rule the maximum fluid velocities are as follows: 5 ft/s for the suction line and 7 ft/s for the discharge line.

**NOTE:** Restriction of the suction pipe work may cause cavitation, leading to a loss of efficiency and rapid wear.

**b)** Any possibility of an air pocket (*piping "U" bend, concentric reducers etc.*) or air entrance in the suction line must be avoided.

**c)** All piping must be connected to the pump without forcing. All pipe work should be properly supported (*free standing.*) Additionally, flexible pipe connections should be if thermal cycling is possible (*e.g. outdoor installations*) to prevent pipe stress.

**d)** The suction and discharge piping must be cleaned of any foreign objects and flushed before connections are finalized.

**e)** Mounted pipe lines must be checked to ensure proper sealing, particularly on the suction pipe.

**f)** Keep the suction pipe as short and straight as possible.

**g)** Use rigid or reinforced pipe that will not deform or collapse under suction conditions.

**h)** Gate or check valves should be installed if there is any possibility of water hammer when the pump is shut down.

**i)** A pressure relief regulator with by-pass (*or LINEMAN pump protector*) is recommended if excessive pressure is probable.

**j)** A pressure gauge with gauge guard is recommended (*near the pump discharge port*) for monitoring system parameters.

**NOTE:** Dead-head operation will damage the pump and over-load the drive.

## **OPERATION:**

Two conditions are critical when operating a mag-drive pump:

**DO NOT RUN THE PUMP FOR AN EXTENDED PERIOD OF TIME WITHOUT FLUID IN THE PUMP!**

**DO NOT DEAD-HEAD THE PUMP!**

1) Fill the pump body with liquid before starting the unit. If pump has flooded suction, open the suction valve. If the unit is priming, pump should be filled through the top port.

**NOTE:** If the fluid is extremely hot or cold, the pump should be gradually brought to operating temperature before the fluid is introduced to prevent possible thermal shock damage.

2) If the unit is long-coupled, the bearing frame housing should contain the proper oil at the proper level. The unit must also be properly aligned. Consult the **BEARING FRAME OPERATION AND MAINTENANCE INSTRUCTIONS** before proceeding.

3) Consult the **MOTOR OPERATION AND MAINTENANCE INSTRUCTIONS** for wiring, and other driver information.

4) When the pump is ready to run, bump start the motor to check rotation (*see Figure 1*) To change the suction and discharge ports, simply rotate the pump head 180 degrees. Operating the pump in reverse rotation will result in reduced performance, and will damage the pump.

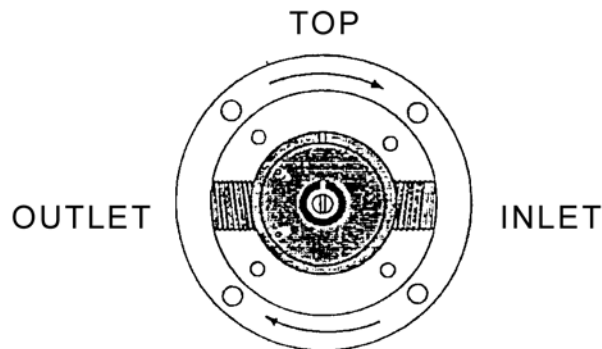

**Figure 1:** Direction and Port Location is Reversible

Check the **MOTOR OPERATION AND MAINTENANCE INSTRUCTIONS** if rotation is not as indicated.

## **MONITORING:**

Flow metering or power sensing relays are strongly recommended to prevent unsuitable operation conditioned (*i.e. dead-heading, dry-running, cavitation, etc.*) Current amp sensors are not advisable. Consult with your local sales representative of Warrender pump division for appropriate minimum and maximum flow limits for a specific pump model. Maximum flow settings often are contingent upon the NPSH available from the system.

## **ESSENTIAL RUNNING PRECAUTIONS:**

### **A) DO NOT RUN THE PUMP DRY!**

The self-lubricating characteristic of the carbon graphite cartridge allows the pump to run dry for a limited amount of time. The process fluid acts as the lubricating and cooling agent, and is required for proper pump operation.

**B) DO NOT DEAD-HEAD THE PUMP!**

In general, the inlet and discharge lines should not be restricted any more than necessary. Restricting the suction line may lead to cavitation, or if completely blocked, a dry run. Restricting the discharge pipe may overload the motor (*a rotary vane pump requires more power with increasing head.*) If completely obstructed (*dead-head*), the fluid will not cool or lubricate the bearings properly. Consult the factory on minimum flow.

**C) DO NOT PUMP FLUIDS WITH FERRO-MAGNETIC PARTICLES!**

Magnetic particles will collect on the internal magnet - regardless of size. Consult the factory for guidance when handling magnetic solids or fines.

**D) PUMP FLUIDS THAT ARE CLEAN**

Mag drive pumps are designed to handle clean liquids. If particulates are present, a 50 to 100 micron suction strainer is recommended. If the concentration of solids might plug strainer, make sure that the suction fluid flow is not impeded. Consult factory for assistance.

**E) FLOW BY-PASS LINES:**

Throttling a rotary vane pump is not the best way to control fluid flow. Throttling may induce unnecessary head, which may in turn overload the motor. Rotary vane pumps have a minimum flow requirements. Applications that require throttling must be checked by the factory. The best way to control the flow of a turbine pump is to run a by-pass line. The by-pass line should run from the discharge of the pump preferably back to the supply tank (*although return to suction may be used.*) Line fluid velocity of 7 ft/s is indicated (*see also Figure 2.*)

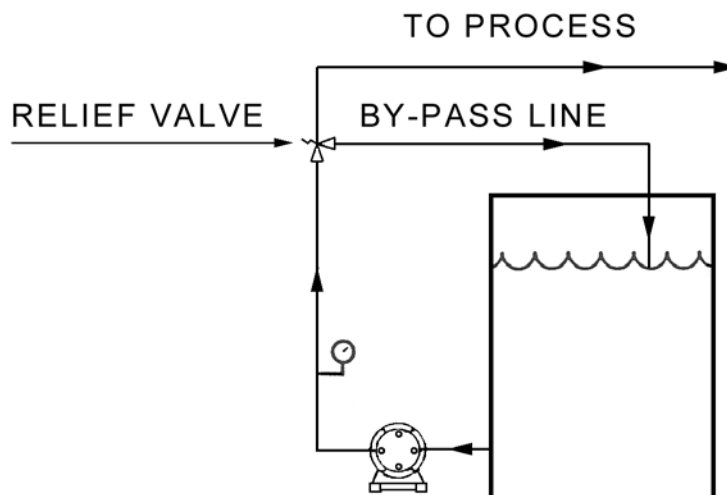

**Figure 2:** By-pass Configuration

**F) FLUSHING THE PUMP:**

The pump should be flushed with water (*or other fluid compatible with the pump materials*) to remove deposits from drying or precipitation. Deposits may form if the unit is down for an extended period of time, or if the pump is cooled to the point where crystals form. The pump does not need to be operating while being flushed. If the pump is to be flushed while in operation, the volume of water should be adequate for the particular unit (*if the operational pump flow is 10 GPM , it should be flushed with 10 GPM of water.*)

**MAINTENANCE:**

In general, the WARRENDER MP series pump does not require routine maintenance, and therefore does not need to be dismantled frequently. However, it is advisable to check the cartridge and O-rings once every year (*shut down periods are best for this.*)

## DISMANTLING THE PUMP:

It is advisable to remove the pump head from the rest of the unit, rather than attempting a back pull out. Small internal parts are lost easily, and manipulation of the head greatly assist re-assembly.

- 1) Shut off power to the motor before disconnecting leads.
- 2) Drain the fluid from the system, and the pump, then isolate the unit. It may be necessary to blow down the pump to insure complete drainage. The pump may be flushed with water (*or compatible fluid*) to avoid deposit formation.
- 3) Remove screws securing the pump body to the bracket.
- 4) Carefully guide the pump head. It may be advisable to have another operator assist in the removal by grasping the pump end.

**CAUTION:** MAGNETS CAN PRODUCE STRONG MECHANICAL FORCES WHEN THEY ARE CLOSE TOGETHER!

- 5) With the pump head moved to the bench, and removal of the internal magnet securing pin, separate the internal magnet from the rotor using an appropriate bearing puller (*this insures that the internal magnet pulls straight off, so as not to bend the rotor shaft*).
- 6) With the internal magnet removed, the internal parts may be taken out. Remove the bolts that secure the end cover the pump body. Remove end cover and internal O-ring.
- 7) To ease graphite cartridge removal, heat the pump body in hot water and allow for expansion. **DO NOT USE A TORCH TO HEAT THE PUMP BODY DIRECTLY.** Pressing on the end of exposed rotor shaft by hand should push out the rotor and front graphite flange.

**CAUTION:** Graphite cartridge is brittle, do not impact, or the unit may break into jagged pieces and **WEAR SAFETY GOGGLES.**

If the cartridge does not free itself by hand, use an arbor press and step shims (*see Figure 4a*), press the rotor and front graphite flange from the pump body. At this time the rotor, vanes and pins may also be removed.

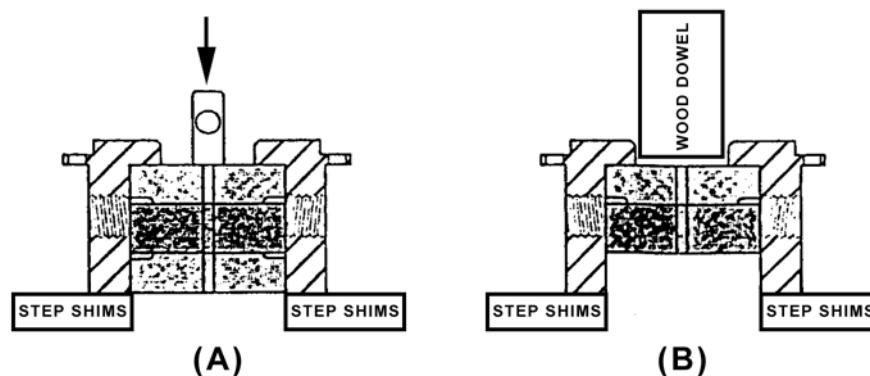

**Figure 4:** Pressing cartridge with arbor press and step shims

- 8) To complete the cartridge removal, by hand, press out the remaining stator and rear graphite flange. If these parts do not release, use an appropriately sized wooden dowel and an arbor press with step shims to press out these parts (*see Figure 4b.*)

**NOTE:** THE POSITION OF THESE PARTS, in particular the fashion in which the end cover, graphite cartridge, and rotor are assembled.

- 9) Examine the cartridge for wear, and the O-ring for deterioration.

## REASSEMBLING THE PUMP:

To reassemble the pump, simply reverse the order in which the pump was disassembled. Since this pump does not have smaller parts, the following should be used as a guide.

- 1) To ease graphite cartridge installation, heat the pump body in hot water and allow for expansion,

**DO NOT USE A TORCH TO HEAT THE PUMP BODY DIRECTLY.**

- 2) Remove the pump body from the hot water, and place pump body on flat surface with internal cavity facing upwards.
- 3) Insert a stiff 10 gauge wire into the guide wire hole located inside the internal cavity at the bottom. This wire will assist in correct alignment of the graphite flanges and stator.
- 4) With the wire inserted into the guide hole, properly align and insert the rear graphite flange into the pump body with the flat side down, and the re-circulation holes on the side corresponding to the DISCHARGE (see **Figure 5**.) Note that the front graphite flange has a recessed groove for an O-ring.

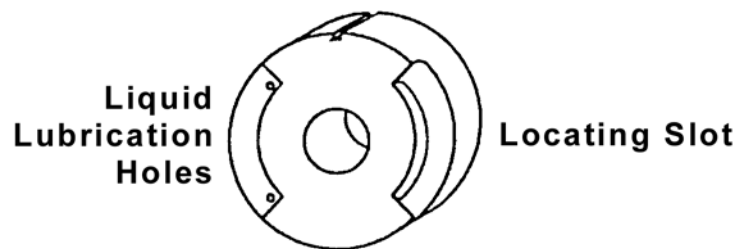

**Figure 5:** Graphite Flange Position

- 5) Slide the graphite stator into the pump body using wire as a guide in the stator slot.

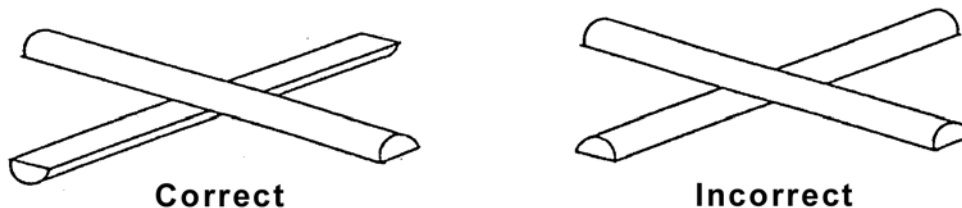

**Figure 6:** Pin Placement

- 7) Insert the vanes into the rotor slots noting that the curved edge of the vane faces towards the graphite stator. The vanes should seat with a close sliding fit (*the vanes will barely support themselves in the rotor slots.*) If the vanes cannot be inserted, or do not slide easily, the side panels should be lightly sanded with fine grit emery paper.
- 8) Grasping the rotor with vanes installed, insert the assembly (*shaft end first*) into the pump body.
- 9) Gently remove the guide wire from the pump body, and insert the locating pin into the guide wire slot.
- 10) Align and insert the front graphite flange into the pump body, and insert the locating pin into the pump body with the flat side down, and the recirculation holes on the side corresponding to the DISCHARGE (see **Figure 5**).

**Note:** The front graphite flange has a recessed groove for an O-ring that faces towards the end cover plate.

**11)** Install the front O-ring, then correctly place and bolt the end cover on the pump body, as it was removed.

**12)** Slide the internal magnet on the rotor shaft. Be sure not to cock the rotor/internal magnet assembly, or else the rotor shaft may bend. If the magnet does not slide on easily, an arbor press may be used.

**Note:** The pump requires that the securing pin holes line up on the internal magnet and rotor shaft. Insert the securing pin.

**13)** Insert the assembled pump head back into the bracket assembly with the rear casing and O-ring already in place.

**For more information please contact:**



**WARRENDER, LTD.**

WARRENDER Pumps

28401 N. Ballard Dr. Suite H.

Lake Forest, IL 60045

Ph:(847) 247-8677 Fax:(847) 247-8680

www.warrender.com email:sales@warrender.com

***Seal-less Mag-drive Pump Specialists***