

# MCSP SERIES SEAL-LESS CENTRIFUGAL PUMPS

## INSTALLATION, OPERATION, AND MAINTENANCE INSTRUCTIONS

TO OBTAIN THE BEST PERFORMANCE FROM YOUR WARRENDER MCSP PUMP,  
PLEASE READ THE MANUAL CAREFULLY.

**Failure to follow the recommended procedures may result in early and severe damage to your WARRENDER pump, and may also invalidate the warranty.**

Thank you for your purchase of a WARRENDER MCSP series self priming centrifugal pump. Proper installation and maintenance will provide many years of trouble free operation.

### **INSTALLATION:**

**1) LOCATION:** Locate the pump close to the liquid source.

**2) PRIMING:** The MCSP pump is designed to self-prime. However, the pump body **MUST** be filled with the proper amount of priming liquid before starting the pump. This pump is not designed to prime from dry! The following list the proper priming fluid volumes:

MCSP 27501-2-3	0.8
MCSP 50501-2-3	1.3
MCSP 80501-2-3	1.6

### **3) SYSTEM PIPING:**

**a)** The nominal diameters of the pump ports shall not be taken as reference for piping size selection. The pipe diameter shall be selected according to the involved capacity and associated frictional losses. The inlet pipe should be no smaller in diameter than the nominal size of the pump inlet port. As a general rule the maximum fluid velocities are as follows: 5 ft/s for the suction line and 7 ft/s for the discharge line.

**NOTE:** Restrictions of the suction piping system may cause cavitation, leading to a loss of efficiency and rapid wear.

**b)** Any possibility of an air pocket (*piping "U" bend, concentric reducers etc.*) or air entering the suction line must be avoided.

**c)** All piping must be connected to the pump without the use of force. All piping system should be properly supported (*free standing.*) Additionally, flexible pipe connections should be installed if thermal cycling is possible (*e.g. outdoor installations*) to prevent pipe stress.

**d)** The suction and discharge piping must be cleaned of any foreign object and flushed before the connections are finalized.

**e)** Mounted pipe lines must be checked to insure proper sealing, particularly on the suction pipe

**f)** Keep the suction pipe as short and straight as possible.

**g)** Use rigid or reinforced pipe that will not deform or collapse under suction conditions.

**h)** Gate or check valves should be installed near the pump discharge if there is the possibility of water hammer when the pump is shut down.

**i)** A pressure relief regulating valve with by-pass (*or Lineman power sensing relay*) are recommended if excessive discharge pressure is probable.

**j)** A pressure gauge with gauge guard is recommended (*near the pump discharge port*) for monitoring system parameters.

**NOTE:** Dead-head operation will damage pump and over-load drive.

## **OPERATIONS:**

Two conditions should be avoided:

**DO NOT RUN THE PUMP WITHOUT FLUID!**

**DO NOT DEAD-HEAD THE PUMP!**

1) Fill the pump body with liquid before starting the unit. Since the unit is priming, the pump should be filled through the priming port. If the pump has a flooded suction, open the suction valve.

**NOTE:** If the fluid is extremely hot or cold, the pump should be gradually brought to rating temperature before the fluid is introduced to prevent possible thermal shock age.

2) If the unit is long-coupled, the bearing frame housing should contain the proper oil at the proper level. The unit must also be properly aligned. Consult the **BEARING FRAME OPERATION AND MAINTENANCE INSTRUCTIONS** before proceeding.

3) Consult the **MOTOR OPERATION AND MAINTENANCE INSTRUCTIONS** for wiring, and additional information.

4) When the pump is ready to run, bump start the motor to check rotation (*see Figure 1.*) Operating the pump in reverse rotation will result in reduced performance, and will damage the pump.

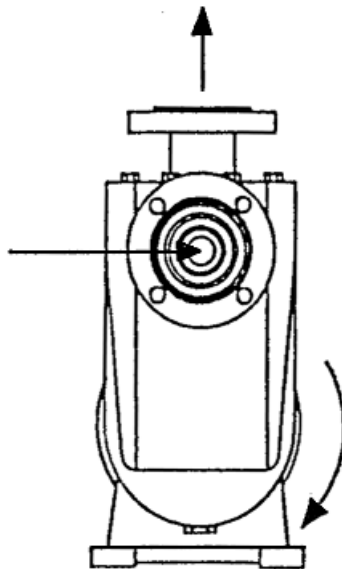

**Figure 1:** Direction and Port Location

Check the **MOTOR OPERATION AND MAINTENANCE INSTRUCTIONS** if rotation is not as indicated.

**MONITORING:**

Flow metering or power sensing relays are strongly recommended to prevent unsuitable operation conditioned (*i.e. dead-heading, dry-running, cavitation, etc.*) Current amp sensors are not advisable. Consult with your local sales representative of Warrender pump division for appropriate minimum and maximum flow limits for a specific pump model. Maximum flow settings often are contingent upon the NPSH available from the system.

**ESSENTIAL RUNNING PRECAUTIONS:**

**A) DO NOT RUN THE PUMP DRY!**

The process fluid acts as the lubricating and cooling agent. Without fluid in the pump, frictional forces generates heat which may damage the pump.

**B) DO NOT DEAD-HEAD THE PUMP!**

In general, the inlet and discharge lines should not be restricted any more than necessary. Restricting the suction line may lead to cavitation, or if completely obstructed (*dead-head*), the fluid will not cool or lubricate the bearings properly. Consult the factory for minimum flow requirements.

**C) DO NOT PUMP FLUIDS WITH FERRO-MAGNETIC PARTICLES:**

Magnetic particles will collect on the internal magnet - regardless of size. Consult the factory for guidance when handling magnetic solids of particulates.

**D) PUMP FLUIDS THAT ARE CLEAN:**

Mag-drive pumps are designed to handle clean liquids. If particles are present, a 50 to 100 micron suction strainer is recommended. If the concentration of solids might plug strainer, make sure that the suction fluid is not impeded. Consult factory for assistance.

**E) FLOW BY-PASS LINES:**

The MCSP series centrifugal pump may not be throttled to the desired duty point ONLY if that point is on the pump curve. Throttling will reduce the power required by the pump, and will reduce the NPSH. In certain cases the pump must be operated at the desired duty point using throttling. If desired flow rate cannot be achieved by throttling, the pump should have a by-pass line. The by-pass line should have a fluid velocity of 7 ft/s. An illustration of what this should look like is shown if **Figure 2**.

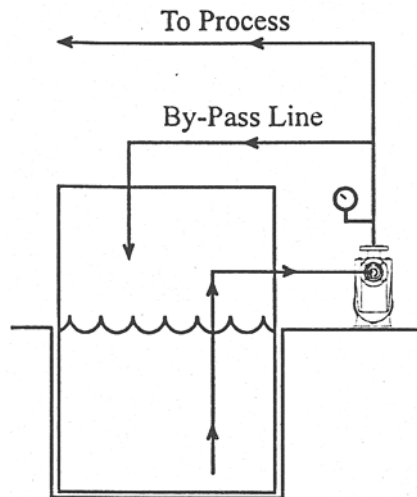

**Figure 2:** By-pass Configuration

**F) FLUSHING THE PUMP:**

The pump should be flushed with water (*or fluid compatible with the pump materials*) to remove deposits from drying or precipitation. Deposits may form if the unit is down for an extended period of time, or if the pump is cooled to the point where crystals form. If the pump is to be flushed while in operation, the volume of water should be adequate for the particular unit (*operational pump flow is 20 GPM max., it should be flushed with a minimum of 10 GPM of liquid.*)

## **MAINTENANCE:**

In general, the WARRENDER MCSP series pump does not require routine maintenance, and therefore does not need to be dismantled frequently. However, it is advisable to check the impeller and bearings once every year (*during a scheduled shut down.*)

## **DISMANTLING THE PUMP:**

The motor bracket are withdrawn from the pump end (*this allows the piping system to remain intact on intact on the volute.*)

- 1) Shut off the power to the motor before disconnecting the leads.
- 2) Drain the fluid from the system, and the pump, then isolate the unit. It may be necessary to blow down the pump to insure complete drainage. The pump may be flushed with water (*or compatible liquid*) to avoid deposit formation.
- 3) Remove the bolts that secure the pump head to the bracket.
- 4) Remove the motor from the bracket by loosening the bolts that secure the bracket to the foundation.
- 5) Carefully guide the bracket away from the pump head. Do not angle or use a side-to-side motion to remove the bracket from the pump, as this may damage the pump. At this point the pump internals should retain in the bracket housing. It is advisable to have an operator stand-by to assure that the internals do not drop out on to the foundation. **Models MC50001-2-3 and MC80001-2-3** have a metal ring behind the rear casing, this ring is to be **SAVED**. The ring is required for proper tolerances, and is not included as a part with a Rear Wet End or Wet End.

**NOTE:** THE POSITION OF THESE PARTS: Especially the placement of the small Ceramic ring in the eye of the impeller. The placement of the rear ring in the rear casing, and the flow baffle attached to the pump head.

**CAUTION:** MAGNETS CAN PRODUCE STRONG MECHANICAL FORCES WHEN THEY ARE CLOSE TOGETHER!

- 6) Examine the shaft, bearings, and the impeller for signs of wear. Also check for minimal play. Examine the O-ring.

## **REASSEMBLING THE PUMP:**

To reassemble the pump, simply reverse the order above according to the procedure. Once again it must be stated that care should be taken when the internal and external magnets are brought together. For larger MCSP pumps (*MCSP 27501 and above*) the use of a wedge may be advised. The wedge (**shown in Figure 3**) allows for slow guided insertion of the pump internals into the bracket.

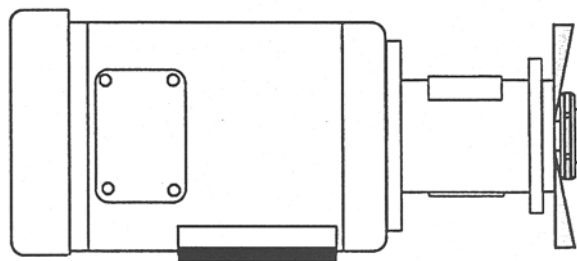

**Figure 3:** Wedge Sample

## **SPECIAL MAINTENANCE PROCEDURES:**

Occasionally parts only require replacement, and this section will demonstrate the proper procedures to follow. Remember, these are to replace worn or broken parts, not to perform for practice.

### **Sleeve Bearing Replacement:**

1) Remove the bearings from the pump head, rear casing, and internal magnet.

**NOTE:** If the bearing in the rear casing needs replacement, the shaft must be removed first  
(See *Shaft Replacement*, and take special care to pad the shaft.)

To remove the bearing from the rear casing of these models, insert a large flat head screwdriver into the bearing. Push the screwdriver into the bearing until it bites into the bearing material. Twist and pull bearing loose.

**CAUTION:** Do not use too large of a screwdriver that will cause the bearing seat to break.

2) Insert the new bearings squarely into the pump head, rear casing and internal magnet. Do not use a side-to-side or twisting motion to insert the bearings. If an arbor press is to be used, be sure to pad the bearing to avoid breakage .

### **Shaft Replacement:**

1) Cushion the shaft with fiber reinforced gasket material. Regular gasket material may twist out of the vise.

2) Place the shaft into the vise, tighten vise, and twist/pull shaft out. If the shaft has shattered, and is not long enough to put into the vise, pull shaft out with channel locks or pliers. If the shaft is too short for pliers, it must be broken out. If this last option is necessary, be careful not to damage the rear casing - **WEAR SAFETY GOGGLES.**

3) Insert the new shaft into the bearing in the rear casing. If an arbor press is used, be sure to cushion the end contacting the shaft. The shaft for these pumps will bottom-out when it is fully inserted. There is only one shaft supplied for this pump design.

### **Rear Ring Replacement:**

**NOTE:** All the centrifugal self-primers have an impeller locking pin that must be removed before the impeller is to be removed. Use a properly sized punch and tap the pin free of the impeller. This pin should be **SAVED**, as it is not included with a replacement impeller.

1) Insert the boxed end of two wrenches against the impeller and the internal magnet. These ends should be cushioned, so as not to deform the impeller, rear ceramic ring, or internal magnet.

2) Apply force on the wrenches against the impeller to pop the impeller from the internal magnet.

Placing the assembly on a raised surface may provide additional leverage (**See Figure 4.**)

3) At this time the rear ceramic ring assembly may be removed from the impeller magnet assembly.  
(For replacement of a damaged ceramic ring or impeller rear bearing, see *Thrust Bearing Replacement* section.)

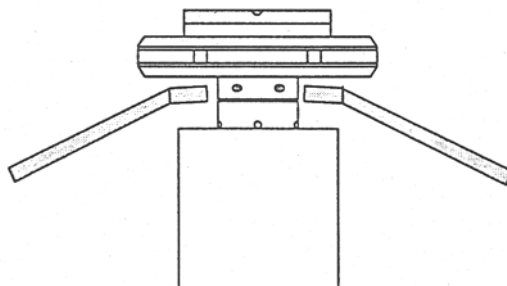

**Figure 4:** Impeller Removal Example

### 3)cont.

To assemble, replace the rear ring on the impeller magnet with the ceramic ring facing towards the impeller rear ring. Place the impeller on with the smaller thrust bearing towards the internal magnet. Be sure to align the impeller so that it slides over the proper guide pins so that the locking pin may be inserted. If an arbor press is used, be sure to cushion the end contacting the impeller. (*note that the front and rear thrust bearings must be on the impeller before installation.*) Insert the impeller locking pin to the proper depth.

### Thrust Bearing Replacement :

Two sets of thrust bearings are found in every WARRENDER self-priming centrifugal pump. Two are located on the impeller, and the others are in the pump head and in the rear ring. The bearings on the impeller may need changing, while the ceramic ones in the pump head and rear ring last for the life of the pump.

Impeller front and rear thrust bearing replacement:

- 1) Insert a flat head screwdriver into the side of the bearing, and lift off.
- 2) The new bearing may be pressed in by hand, noting the position of the guide pins.

Pump head and rear ring ceramic front and rear thrust bearing replacement:

- 1) Insert an appropriately sized punch into the suction port of the pump (*or internal hole in the rear ring.*) Gently tap the ceramic lip of the bearing evenly, so that the unit frees itself from the pump head. Note that there are two components that make up this bearing. If the bearing is cracked (or broken) carefully break the ceramic front thrust bearing apart, take care not to damage the shaft support in the pump head (*or thermoplastic rear ring*) and **WEAR SAFETY GOGGLES.**
- 2) Lubricate the exterior of the elastomer of the bearing with a material that is compatible with the process fluid. Also lubricate the slot where the bearing slides into the pump head or rear ring. Noting that the polished side faces out of the pump head (*or towards the impeller concerning the rear ring*), insert the bearing into the slot. If an arbor press is used, be sure to cushion the contacting the ceramic bearing.

For More Information, Please contact:



## WARRENDER, LTD.

WARRENDER Pumps  
28401 N. Ballard Dr. Suite H.  
Lake Forest, IL 60045

Ph:(847) 247-8677  
Fax:(847) 247-8680  
www.warrender.com  
email:sales@warrender.com

**Seal-less Mag-drive Pump Specialists**